

SOCKS PACKAGING

AUTOMATIC PACKAGING LINE FOR SOCKS

TECNOPACK + BAND + BAG 1-3



SOCKS BOARDING TECNOPACK + BAND + BAG 1-3

Automatic modular line for socks packaging with adhesive band and cardboard rider.
System, manually fed, can be equipped with the following working stations:

- Manual loading of single or multipair socks flat or folded
- Rider sewing by means of a Tecnopea EasyRider complete with cardboards magazine and electronic printer
- Alternative option to the sewing by means of a swift tack device
- Tuck-in hook feeding module complete with vibrating hopper
- Stacking of pairs for multiple banding/bagging
- Banding on 1, 2 or 3 pairs
- Stacking of socks with band
- Bagging module producing bags from a polypropylene roll
- Option for bag sealing

SOCKS BOARDING

TECNOPACK + BAND + BAG 1-3

Specifications	Values
Dimensions	3.150 x 5.115 x 2.240 (h)
Air pressure	6 bar
Air consumption	31,2 m ³ /hr
Installed power	3,5 kW
Min. Cycle time	3,5 Sec./pack
Min. Cycle time with band	4,5 Sec./pack
Max sewing thickness	25 mm
Max fastner thickness	70 mm

Features
High productivity
Multiple operations performed by a single operator
Performances and quality consistency
Customizable modular system
Flexibility of use
Advanced electronic handling to control the individual functions and storing the working parameters for each product
Remote access capability for extraordinary technical servicing

SOCKS BOARDING

TECNOPACK + BAND + BAG 1-3

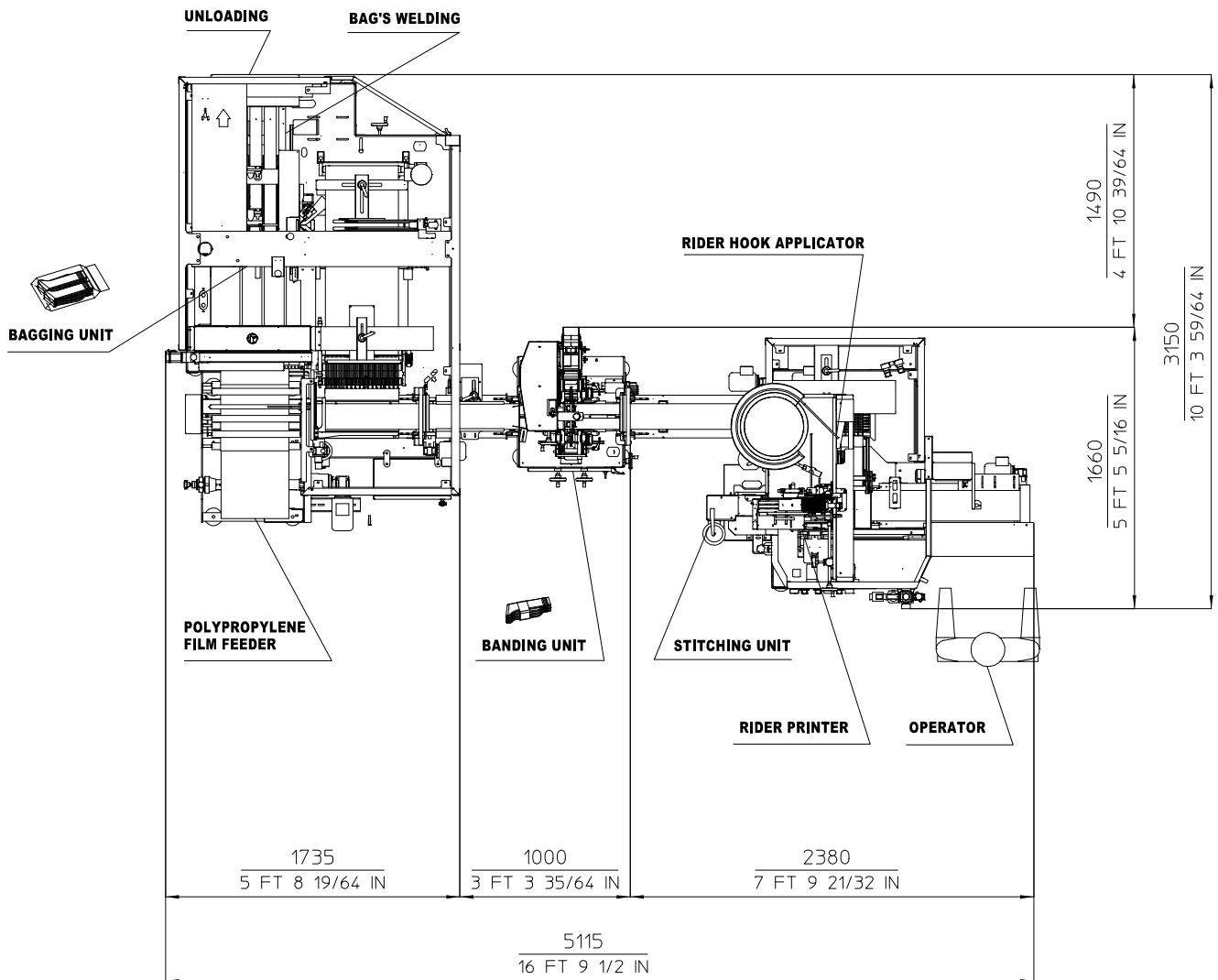
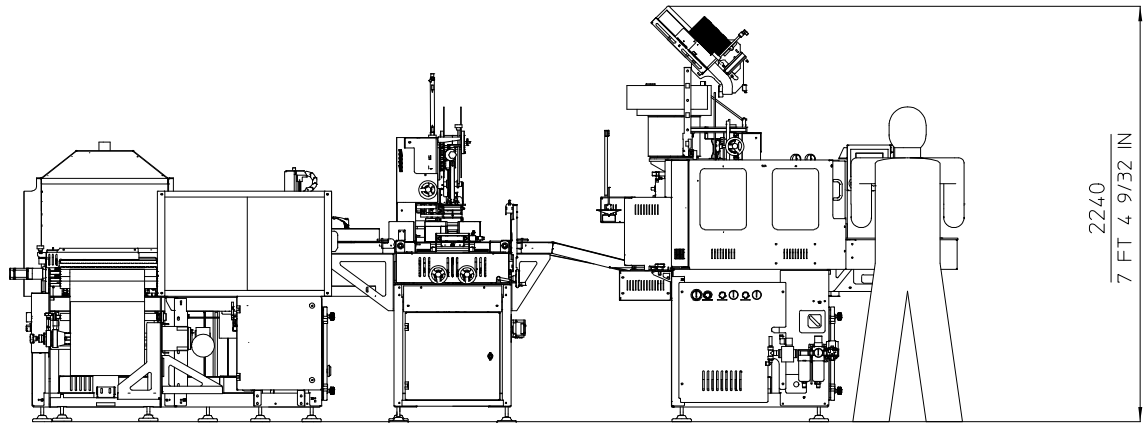

TECNOPEA



TECNOPEA S.R.L.

Via Don Eridano Torri, 2

25027 Quinzano d'Oglio, Brescia - Italy

Tel.: +39 030 992 3780 - Fax: +39 030 9923996

info@tecnopea.com - www.tecnopea.com